

FORKARDT

FNC

*Power Chucks with
Quick Change Jaw System*



WORKHOLDING SOLUTIONS WORLDWIDE

This catalogue describes all components of the FNC universal, quick jaw change, power chucking system.

Should you require further information beyond the data contained in this catalogue, please refer to the following FORKARDT publications:

Chuck jaws

Rotating Actuating Cylinders:

OKRJ closed-centre hydraulic cylinders

OMHJ open-centre hydraulic cylinders

Controllers

Accessories for power chucks

Gripping Force Meters

SKM 1200 / 1500

Contents

FORKARDT FNC

Power Chucks

Page

Power operated chucks with wedge hook in 3-jaw configuration	3
3 FNC	4
Mounting Flanges, Adaptor Flanges, Adaptor Plates	5
Actuating cylinder Jaws and Accessories	6
Jaws and Accessories	7

• For more information visit:

www.forkardt.com

As we are constantly striving to improve our products, the dimensions and specifications in this catalogue cannot always represent the latest state of the art; they are therefore given as an indication only and are not binding.

3 FNC Power chucks

Power operated chuck with quick change jaw system in 3-jaw configuration

The FNC universally applicable power chucks belong to the most efficient and flexible chucks of the FORKARDT range of products. The unique advantage of this type is its quick change jaw system.

The frequent change-over of jaws when processing small size batches continues with this chuck to be economical, due to minimum set-up times needed.

Furthermore, sets of jaws that are already used with the proven manual chucks type F or F+ are 100 % compatible with FNC jaws.

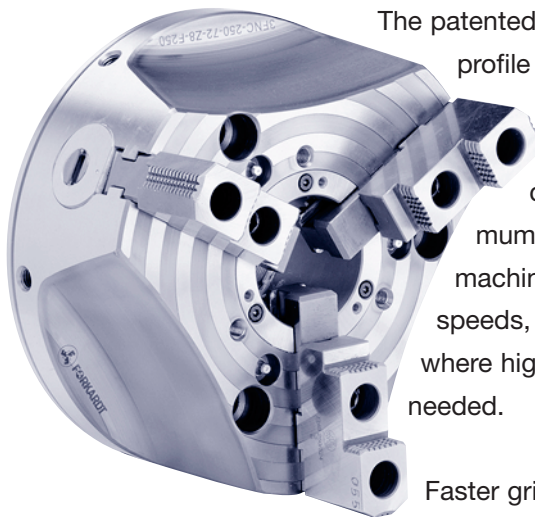

The patented wedge hook profile permits transfer of enormous gripping forces and optimum efficiency when machining at high speeds, especially where high accuracy is needed.

Faster gripping on FNC chucks than on customary quick change jaw chucks is possible due to the shorter stroke of the central actuator for the same jaw movement.

Many possibilities for mounting the FNC exist due to the modular design - thus ensuring compatibility to all common machine spindles.

And of course, all FORKARDT chucks are manufactured from highest quality materials and are produced in accordance with the requirements of ISO 9001:2000.

Technical Features:

- Optimum production efficiencies due to minimal jaw changeover times.
- Highest gripping forces and extreme accuracy.
- High grade, specially heat treated chuck body – one-piece, high strength and highly rigid construction – slim design with weight reducing cutouts.
- Mounting flanges for short taper mounting are available.
- FNC chucks may be equipped with standard jaws (hard or soft), claw jaws or special jaws.

Advantages at a glance:

- Reduction of jaw changeover time to a few seconds.
- Well proven F jaw system can also be used on FNC chucks, so many existing jaw sets can continue to be used.
- Closely maintained concentricity and repetitive accuracy as well as long service life
- Mounting accessories to suit any machine spindle.
- Extremely high gripping forces due to patented heavy duty, trapezoidal wedge hook actuation.

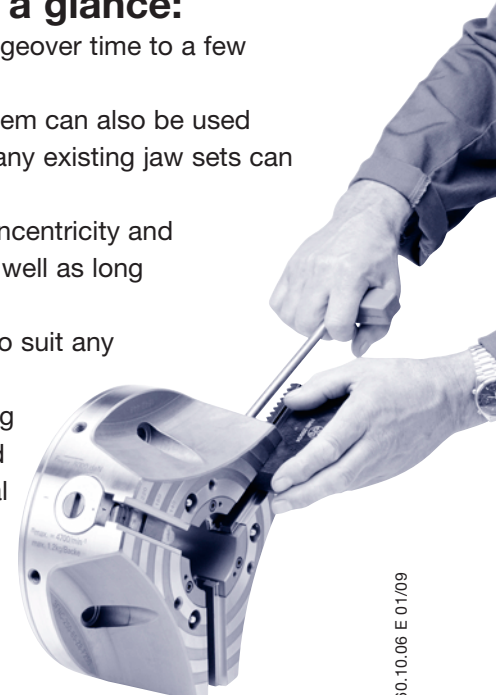

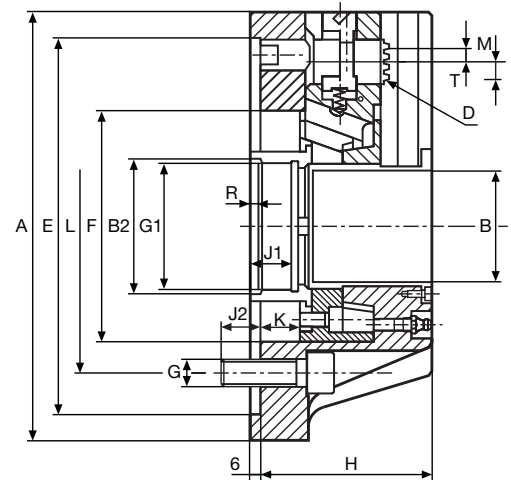
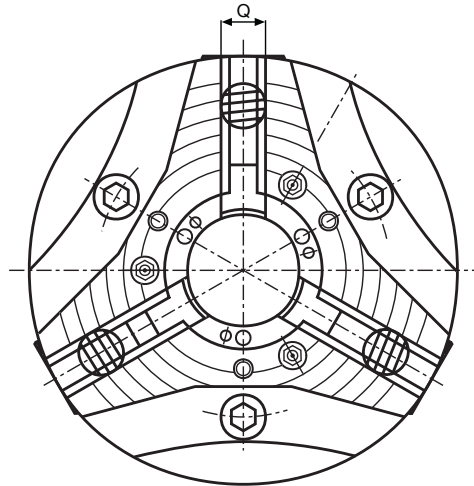
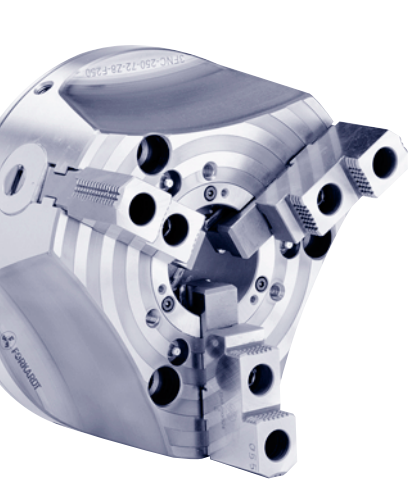

Dimensions / Performance data 3 FNC power chucks

Type	3 FNC		175-42	200-45	250-72	315-82	400-92	500-125	630-125
Dimensions									
Outer diameter	A	mm	180	206	257	315	400	500	630
Bore	B	mm	42	45	72	82	92	125	125
Chuck mounting/Mounting recess	C / E	mm	Z5 / 140	Z6 / 170	Z8 / 220	Z11 / 300	Z11 / 300	Z15 / 380	Z15 / 380
Jaw mounting	D		F 160	F 200	F 250	F 250	F 315	F 400	F 400
Pitch of serration	T		4,8	4,8	6,0	6,0	7,0	8,5	8,5
Actuator Ø	F	mm	90	106	140	150	192	230	230
Mounting bolts	G		M 10	M 12	M 16	M 20	M 20	M 24	M 24
Thread mounting	G1*)		M 50 x 2	M 52 x 2	M 80 x 2	M 92 x 2	M 100 x 2	M 135 x 2	M 135 x 2
Chuck width	H	mm	78	83	100	100	127	138	138
Thread length	J1	mm	22	22	28	28	28	28	28
Thread length	J2	mm	15	18	24	30	30	36	36
Actuator stroke	K	mm	20	20	23	23	28	33	33
Pitch circle	L	mm	104,8	133,4	171,4	235,0	235,0	330,2	330,2
Jaw stroke	M	mm	7,2	7,2	8,3	8,3	10,0	12,0	12,0
Jaw width	Q	mm	20	22	26	26	32	45	45
Mounting recess thread mounting	PH ⁷	mm	51	53	81	94	102	136	136
Width	R	mm	6	6	6	6	6	6	6
Performance data									
Max. actuating force	F _{max}	daN	3.000	4.500	6.000	6.000	10.000	12.000	12.000
Max. gripping force	F _{spmax}	daN	5.500	8.400	12.000	12.000	19.500	24.000	24.000
Max. speed	n _{max}	U / min	7.000	6.300	4.500	4.000	3.300	2.200	1.700
Max. weight top jaw	**	kg / pc.	0.22	0.34	0.74	0.74	2.24	3.6	3.6
Max. jaw height top jaw	**	mm	40	45	58	58	65	85	85
Weight	G	kg	11	15	24	37	68	115	200
Moment of inertia	kg / m ²	kgm ²	0,04	0,09	0,20	0,50	1,50	4,00	11,00
Chuck constant	C1	mm	390	412	580	780	940	1200	1760
	C2	mm	213	221	290	390	482	600	880
	C3	kgm	0,065	0,09	0,187	0,33	0,73	1,66	2,80
Ident-Number									
3 FNC			D159570000	D159571000	D159427000	D159572000	D159575000	D159577000	D159578000

*) Other dimensions on request

**) Limit value for max. speed

Whereby the operating gripping force F_{sp0} at idle (at speed n = 0) is:

$$F_{sp} = \frac{C1}{C2 + a} \times Fax \pm 0,0008 \times (C3 + Ma) \times n^2 \text{ [daN]}$$

Terms used in the equation:

F_{sp} = operating gripping force [daN], the sum of the gripping forces of the jaws at operation.

C 1, C 2, C 3 = Chuck constants

Fax = Actuating force [daN]

Mounting flanges and adaptor plates:



Flanges with bayonet plate attachment for mounting on spindle J noses to DIN 55022, DIN 55027, ISO 702 / III

Chuck type	Spindle nose	Flange type	Ident-No.	Dimensions				Studs and collar nuts		
				B	D	L1	L2	FN	Ident-No.	Qty.
FNC	Size									
	4	FF140-J4	D1074085000	50	18	104,8	85,0	322	D1070504000	3
175	5	FF140-J5	D1074086000	50	24	104,8	104,8	322	D1070505000	4
	5	FF170-J5	D1074089000	60	24	133,4	104,8	322	D1070506000	4
200	6	FF170-J6	D1074090000	65	28	133,4	133,4	322	D1070506000	4
	6	FF220-J6	D1074096000	80	28	171,4	133,4	322	D1070506000	4
250	8	FF220-J8	D1074097000	80	32	171,4	171,4	322	D1070507000	4
	6	FF220-J6	-	100	28	171,4	133,4	322	D1070506000	4
315-82	8	FF220-J8	-	100	32	171,4	171,4	322	D1070507000	4
	8	FF300-J8	D1074103000	90	32	235,0	171,4	322	D1070507000	4
400	11	FF300-J11	D1074104000	90	35	235,0	235,0	322	D1070508000	6
	11	FF380-J11	D1074107000	120	35	330,2	235,0	322	D1070508000	6
500	15	FF380-J15	D1074108000	120	42	330,2	330,2	324	D1070517000	6
	11	FF380-J11	D1074107000	120	35	330,2	235,0	322	D1070508000	6
630	15	FF380-J15	D1074108000	120	42	330,2	330,2	324	D1070517000	6

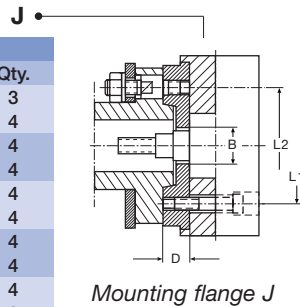

Mounting flange J

Order code example: 1 mounting flange type FF 170-J6, Ident. No. D1074090000; 1 set of studs with collar nuts size 6, Ident-No. D1070506000

Flanges with camlock attachment for mounting on spindle D noses to DIN 55029, ISO 702 / II, ASA B 5.9 D1

Chuck type	Spindle nose	Flange type	Ident-No.	Dimensions				Camlock studs		
				B	D	L1	L2	GN	Ident-No.	Qty.
FNC	Size									
	4	FF140-D4	D1074118000	50	28	104,8	82,6	286	D1070511000	3
175	5	FF140-D5	D1074119000	50	30	104,8	104,8	287	D1070512000	6
	5	FF170-D5	D1074122000	60	30	133,4	104,8	287	D1070512000	6
200	6	FF170-D6	D1074123000	65	35	133,4	133,4	288	D1070513000	6
	6	FF220-D6	D1074129000	80	35	171,4	133,4	288	D1070513000	6
250	8	FF220-D8	D1074130000	80	40	171,4	171,4	289	D1070514000	6
	6	FF220-J6	-	100	35	171,4	133,4	288	D1070513000	6
315-82	8	FF220-J8	-	100	40	171,4	171,4	289	D1070514000	6
	8	FF300-D8	D1074136000	90	40	235,0	171,4	289	D1070514000	6
400	11	FF380-D11	D1074137000	90	45	235,0	235,0	290	D1070515000	6
	11	FF380-D11	D1074140000	120	45	330,2	235,0	290	D1070516000	6
500	15	FF380-D15	D1074141000	120	50	330,2	330,2	291	D1070516000	6
	11	FF380-D11	D1074140000	120	45	330,2	235,0	290	D1070516000	6
630	15	FF380-D15	D1074141000	120	50	330,2	330,2	291	D1070516000	6

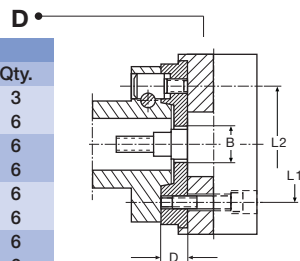

Mounting flange D

Order code example: 1 mounting flange type FF 170-D6, Ident-No. D1074123000; 1 set of camlock studs size 6, Ident-No. D1070513000

Adaptor flanges including mounting bolts for spindle noses to DIN 55021 A/B, DIN 55026 A/B, ISO 702/I A1/A2, ASA B5.9 A1/A2

Chuck type	Spindle nose	Flange type	Ident-No.	Dimensions				Mounting bolts	
				B	D	L1	L2	DIN 912	10.9
FNC	Size								
	4	ZWF140-K4 ■	D164905000	50	18	104,8	85,0	3 x M10 x 20	
175	4	ZWF140-K4 ●	D164906000	50	18	104,8	82,6	3 x M10 x 20	
	5	ZWF170-K5	D164907000	60	24	133,4	104,8	4 x M10 x 25	
200	6	ZWF220-K6	D162896000	80	28	171,4	133,4	4 x M12 x 30	
250	6	ZWF220-K6	D162896000	100	28	171,4	133,4	4 x M12 x 30	
315-82	8	ZWF300-K8	D164908000	90	32	235,0	171,4	4 x M16 x 35	
400	8	ZWF300-K8	D164908000	90	32	235,0	171,4	4 x M16 x 35	
500	11	ZWF380-K11	D164909000	120	35	330,2	235,0	6 x M20 x 40	
630	11	ZWF380-K11	D164909000	120	35	330,2	235,0	6 x M20 x 40	

■ DIN 55021 pitch circle diameter 85 mm ● DIN 55026 pitch circle diameter 82.6 mm

Order code example: 1 adaptor flange ZWF140-K4, Ident-No. D44757000

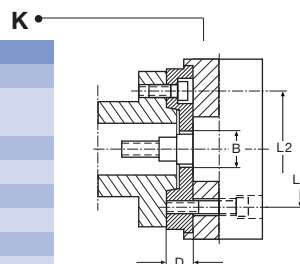

Adaptor flange ZWF

Adaptor plates for spindle noses to DIN 55021 A, DIN 55026 A, ISO 702/I A2, ASA B 5.9

Chuck type	Spindle nose	Flange type	Ident-No.	Dimensions		
				D	L2	L*
FNC	Size					
175	5	ZWS140-K5	D1074035000	14	104,8	10
200	6	ZWS170-K6	D1074036000	15	133,4	15
250	8	ZWS220-K8	D1074038000	17	171,4	15
315	8	ZWS220-K8	D1074038000	17	171,4	15
400	11	ZWS300-K11	D1074040000	19	235,0	20
500	15	ZWS380-K15	D1074042000	21	330,2	20
630	15	ZWS380-K15	D1074042000	21	330,2	20

* The length of the chuck mounting bolts must be increased by the amount "L" when using these adaptor plates!

Order code example: 1 adaptor plate ZWS140-K5, Ident-No. D1074035000

K A2

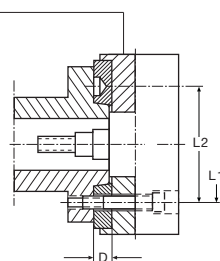

Adaptor plate ZWS

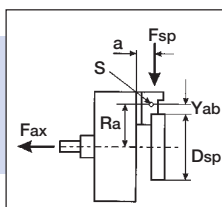

n = Speed [min⁻¹]
 Ma = Total - Centrifugal moment of the jaws [kgm]
 = $\sum G \times Ra$
 Dsp = Gripping Diameter [mm]

Yab = Centre of gravity of the top jaw to the Gripping Diameter [mm]
 a = Jaw overhang [mm]
 G = Weight of one jaw [kg]
 Ra = Distance from the centre of gravity of the top jaw to the chuck centre [mm]

Actuating cylinders

Hydraulic hollow cylinders are used to generate actuating forces for power chucks. The new FORKARDT OMHJ series is ideal for strong and delicate clamping at all speeds.

Key Features:

- Compact reliable, modular design
- Short overall length for easy fitment to lathes
- Advanced bearing and seals design
- Competitive pricing

Other FORKARDT accessories available include:

- Hydraulic cylinders OMHJ (for open centre - clamping).
- Draw tubes and bars, cylinder flanges (machine - related).
- Hard and soft top standard – jaws.
- Roughing jaws.
- Special grease keeping the clamping force.
- Lapping plates for the maintenance of fine serration of chuck jaws.
- Special chuck jaws (work piece – related)

- Highly precise oil feed and coolant drainage systems
- Balanced to class Q = 2.5
- Alternate controlled safety of non-return valves
- Clamping stroke monitoring included as standard
- Continuous clamping stroke monitoring as option
- Developed and produced under ISO 9001:2000

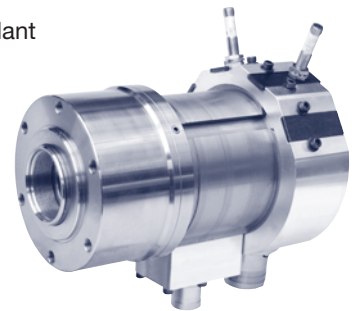

*FORKARDT OMHJ
Hydraulic through hole
cylinder*

Gripping force meters

To ensure the reliable, safe and accurate operation of all chucking systems an accurate gripping force meter is essential. The FORKARDT SKM products are quick, precise and inexpensive.



*Gripping force
meters
SKM 1200 / 1500*

Chuck jaws

Power Chucks of the FNC series are delivered with the jaws of your choice:

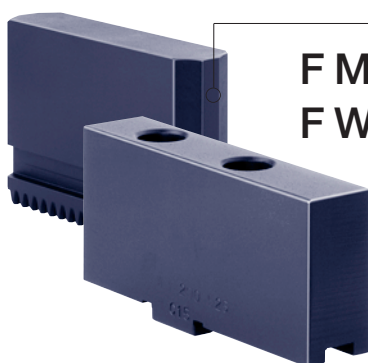

FMB
FWB

Soft top jaws

Soft jaws (type FMB / FWB) are used for the accurate clamping of already machined work pieces, on which clamping surfaces should not be damaged.

These jaws are turned, by the user, under clamping pressure, to the respective clamping diameter to ensure extremely high accuracy and repeatability.



KBKTNC

Roughing jaws

For heavy duty machining of overhanging work pieces roughing jaws KBKTNC with replaceable chucking claws SKA (for external clamping) and SKI (for internal clamping) are available.

The chucking claws provide safest gripping even on short clamp surfaces.

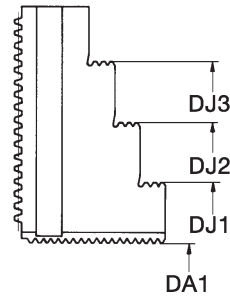
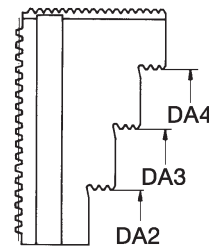
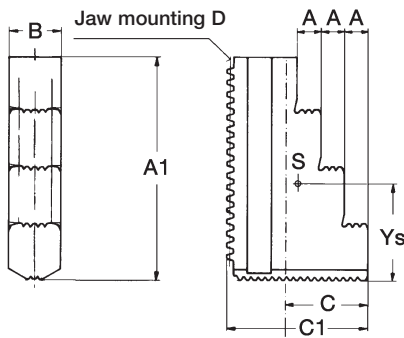

FSTB

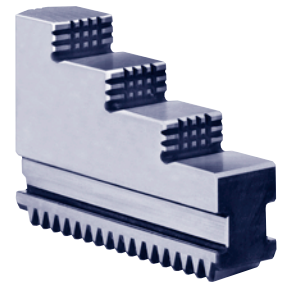

Chuck type UKFST	Max. swing diameter	Jaw type	Nominal dimensions				Ident-No.	a1	a2	a3	a4	c1	For external chucking				For internal chucking			Distance to gravity center Ys	Weight kg/each
			A	B	C	D							DA ₁	DA ₂	DA ₃	DA ₄	DJ ₁	DJ ₂	DJ ₃		
175 - 42	234	160	7,5	20	24	F160	D1070016633	79	23	43	63	45	8-65	59-108	99-148	138-188	63-112	102-152	142-192	35,5	0,350
200 - 45	273	200	10	22	35	F200	D1070021633	94	24	48	72	60	8-76	69-128	116-176	164-224	65-124	113-173	160-220	41,0	0,615
250 - 65	346	250	14	26	40	F250	D1070026533	115	39,7	-	79,9	70	10-101	96-181	-	175-261	96-182	-	176-262	53,0	1,090
250 - 72													10-137	96-217	-	175-297	96-218	-	176-298		
315 - 65													10-137	96-217	-	175-297	96-218	-	176-298		
315 - 82													10-137	96-217	-	175-297	96-218	-	176-298		
400 - 85	462	315	15	32	46	F315	D1070033533	129	37,5	-	92,8	81	40-202	106-276	-	216-386	109-278	-	218-388	59,0	1,770
400 - 92													40-236	150-357	-	272-480	152-367	-	274-480		
500 - 125	586	400	20	45	52	F400	D1070038533	167	52,5	-	113,8	93	110-339	150-459	-	272-582	152-460	-	274-582	75,5	3,600
630 - 125	110-339												150-459	-	272-582	152-460	-	274-582			

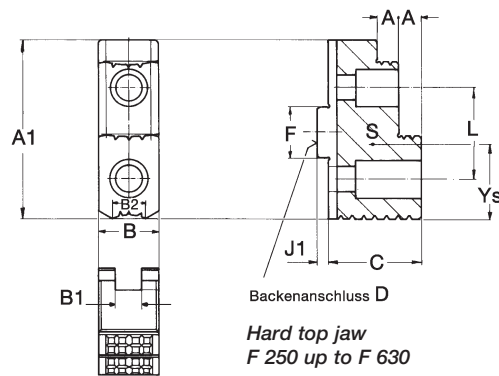
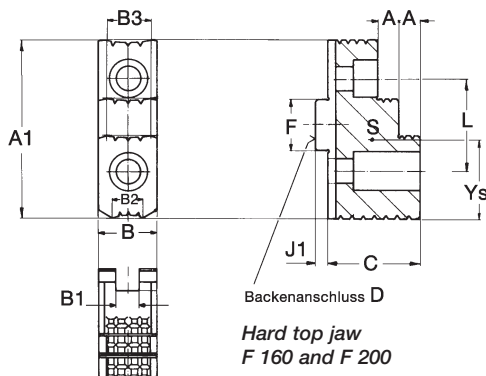

FGB/FHB

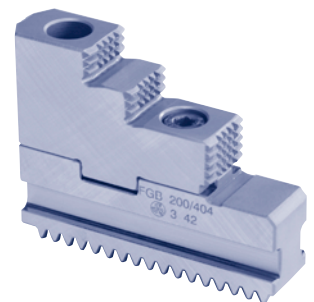

Chuck type UKF	Max. swing diameter	Jaw type	Nominal dimensions				Ident-No.		a1	a2	a3	c1	For external chucking				For internal chucking			Distance to gravity center Ys	Weight kg/each
			A	B	C	D	Base jaw	Top jaw					DA ₁	DA ₂	DA ₃	DA ₄	DJ ₁	DJ ₂	DJ ₃		
175 - 42	234	160	7,5	30	38,5	F160	D70016504	D1070016624	67	33,1	46,2	59,5	8-65	59-108	99-148	138-188	63-112	102-152	142-192	33,9	0,217
200 - 45	273	200	10	30	45	F200	D70021504	D1070021624	75	33,7	47,8	70	8-76	69-128	116-176	164-224	65-124	113-173	160-220	40,3	0,340
250 - 65	346	250	14	32	57	F250	D70026404	D1070026524	90	40,4	80,6	90,5	10-101	96-181	-	175-261	96-182	-	176-262	48,5	0,740
250 - 72													10-137	96-217	-	175-297	96-218	-	176-298		
315 - 65													10-137	96-217	-	175-297	96-218	-	176-298		
315 - 82													10-137	96-217	-	175-297	96-218	-	176-298		
400 - 85	462	315	15	36	64	F315	D70033404	D1070026524	106	37,0	91,3	99	40-202	106-276	-	216-386	109-278	-	218-388	55,3	2,240
400 - 92													40-236	150-357	-	272-480	152-367	-	274-480		
500 - 125	586	400	20	45	85	F400	D70038404	D1070038524					110-339	150-459	-	272-582	152-460	-	274-582	75,5	3,600
630 - 125	110-339												150-459	-	272-582	152-460	-	274-582			

**WORKHOLDING SOLUTIONS
WORLDWIDE**



L O C A T I O N S W O R L D W I D E

FORKARDT DEUTSCHLAND GMBH
Heinrich-Hertz-Str. 7
D-40699 Erkrath
Phone: (+49) 211-25 06-0
Fax: (+49) 211-25 06-221
E-Mail: info@forkardt.com

FORKARDT SCHWEIZ GMBH
Industriestrasse 3
CH-8307 Effretikon
Phone: (+41) 52-3 5531 31
Fax: (+41) 52-3 4352 40
E-Mail: info-ch@forkardt.com

FORKARDT FRANCE S.A.R.L.
28 Avenue de Bobigny
F-93135 Noisy le Sec Cédex
Phone: (+33) 1-41 83 12 40
Fax: (+33) 1-48 40 47 59
E-Mail: forkardt.france@forkardt.com

BUCK CHUCK
2155 Traversefield Drive
Traverse City, MI 49686
USA
Phone: (+1) 231-995-8312
Fax: (+1) 231-941-2466
E-Mail: buck.forkardt@forkardt.com

N.A. WOODWORTH
1391 Wheaton Ave. Suite 700
Troy, MI 48083
USA
Toll Free: 800.544.3823
E-Mail: sales@itworkholding.com
Website: www.itworkholding.com

FORKARDT NORTH AMERICA
1391 Wheaton Ave. Suite 700
Troy, MI 48083, USA
Phone: 248-743-4400
800-794-6190
Fax: 248-743-4401
E-Mail: info@forkardtusa.com

www.forkardt.com

www.itworkholding.com